

DSPIRA Horn Assembly

Design of a low cost and simple radio telescope for use with a Software Defined Radio backend.

Telescope Design

The Horn is designed as an 'optimal' horn, started from 1gallon square paint thinner can (F style metal gallon container), and a largest dimension of 75cm which just fits through a door.



Horn Sides:

The horn sides are made from $\frac{3}{4}$ " aluminized home insulation, which comes in 4x8 ft sheets. The four sides can be cut from a single sheet.

Cut two each following these dimensions (not to scale):

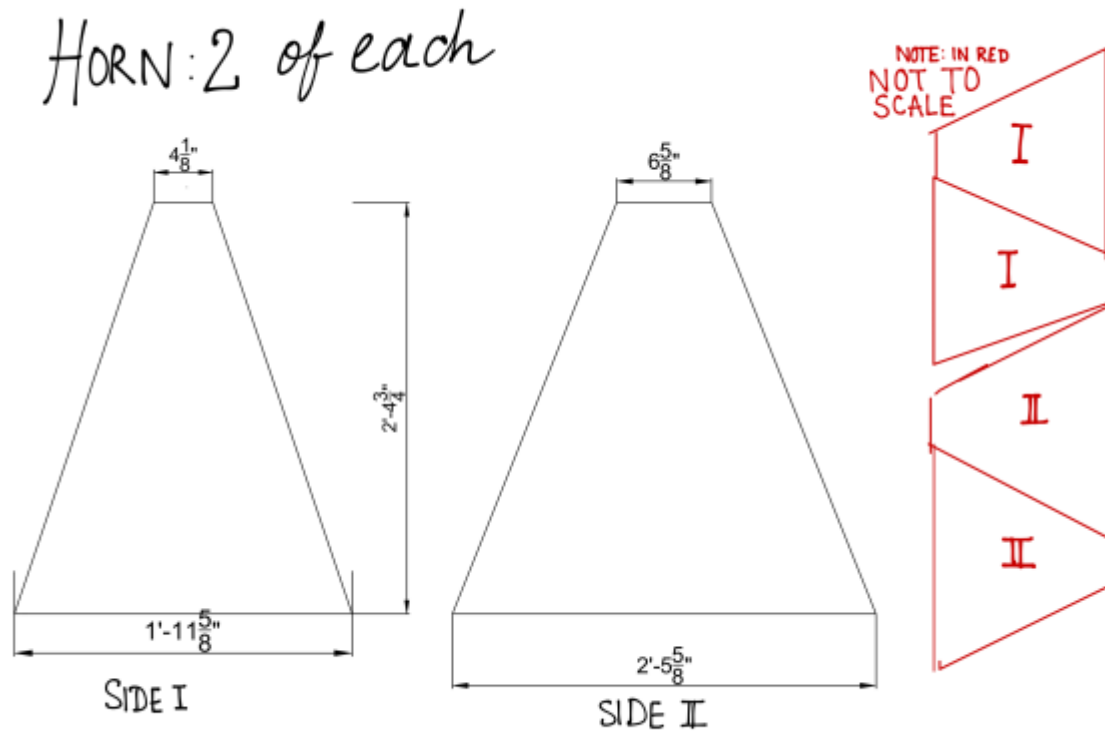

Can

The can top needs to be removed, simplest technique is with a can opener.

The probe is placed 6.5cm (2.56") from the bottom of the can on one of the long sides. The probe should be ~5.25cm long total. Use either a bulkhead type N connector or bulkhead SMA connector, and cut the hole size in the can accordingly.

Assembly

The Horn sides are taped together using aluminum tape on the inside edges, attaching to the aluminum coated side of the insulation. Once the 4 sides are taped, the outside edges can be taped with either aluminum or another non-conductive tape.

After the can probe has been properly attached, attach the can to the horn, again using aluminum tape on the inside, and more of any tape again on the outside.

Mount assembly

The mount is a simple design using 2x4's and 2x2's.

6 3ft long 2x4s

2 ~2ft 2x4 with 45deg cut on one side

1 ~2ft 2x2 cross brace.

2 2ft 2x2

3 6 5/8" 2x2

small ~2" 2x2 spacer

~1.5" 2x2 arm.

4 short, angle cut 2x2.

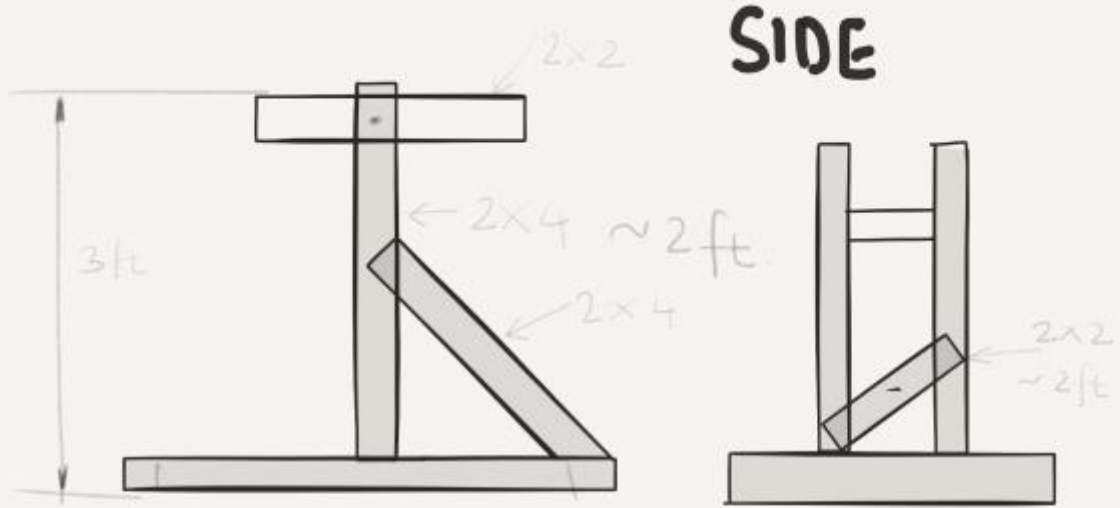

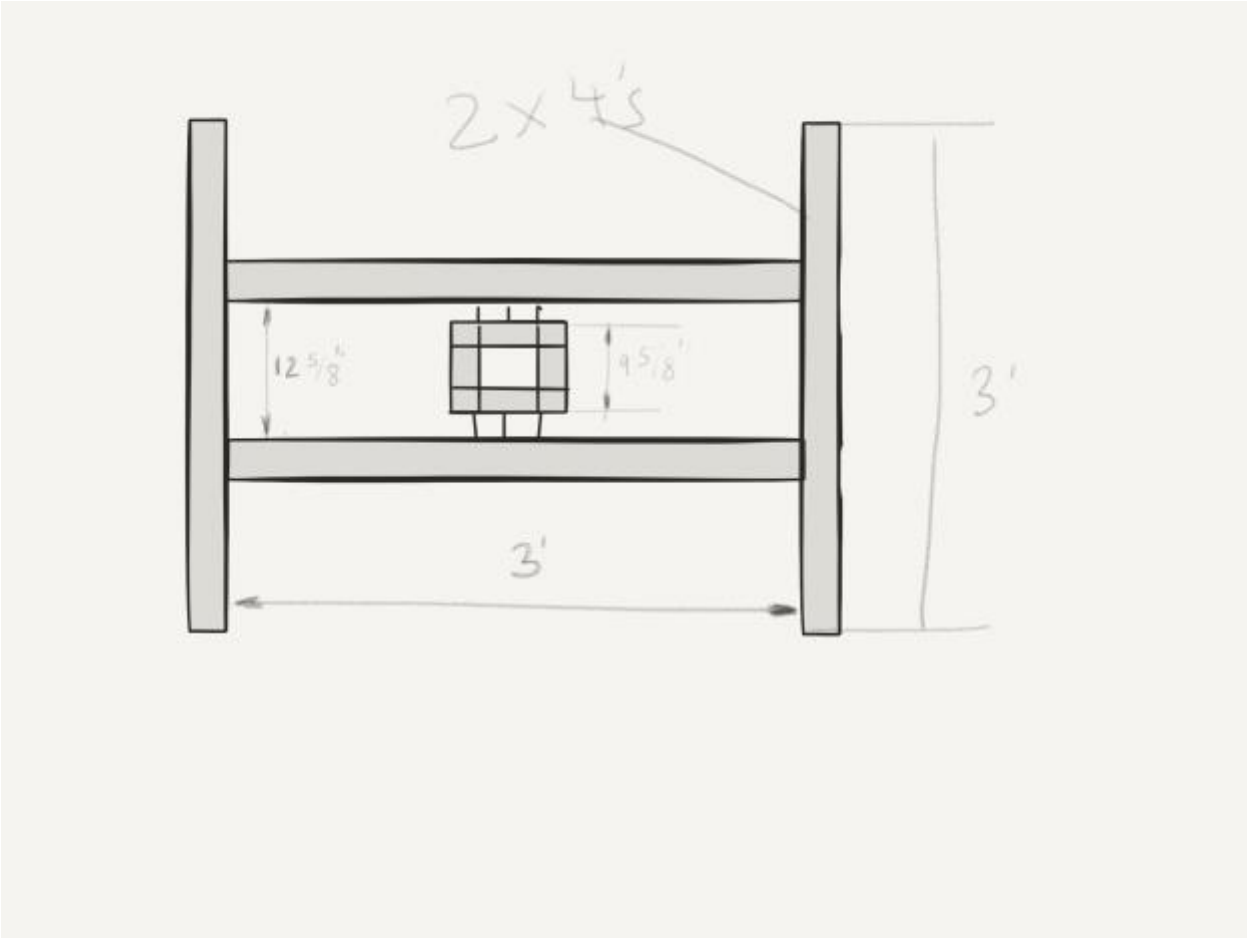

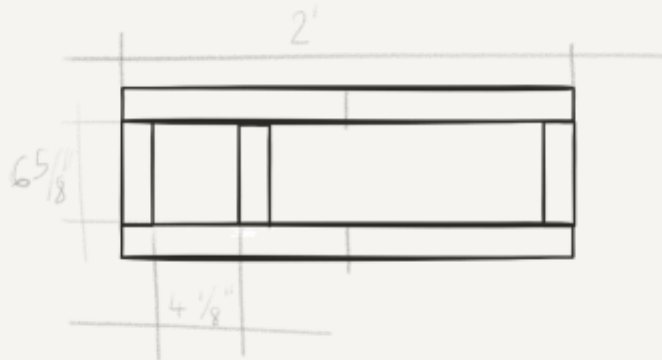

Horn mount additionally has 4 or 8 ~6" angled 2x2 supports for the horn foam.

Elevation control:

The elevation is controlled with another ~1.5ft 2x2 attached to the end of the horn mount next to the can with a small 2x2 spacer (see photo). This is clamped to the uprights to set elevation.

Attach Horn to mount.

The horn just fits inside the mount, and is taped to the 4 supports.

Sample Image of the galaxy:

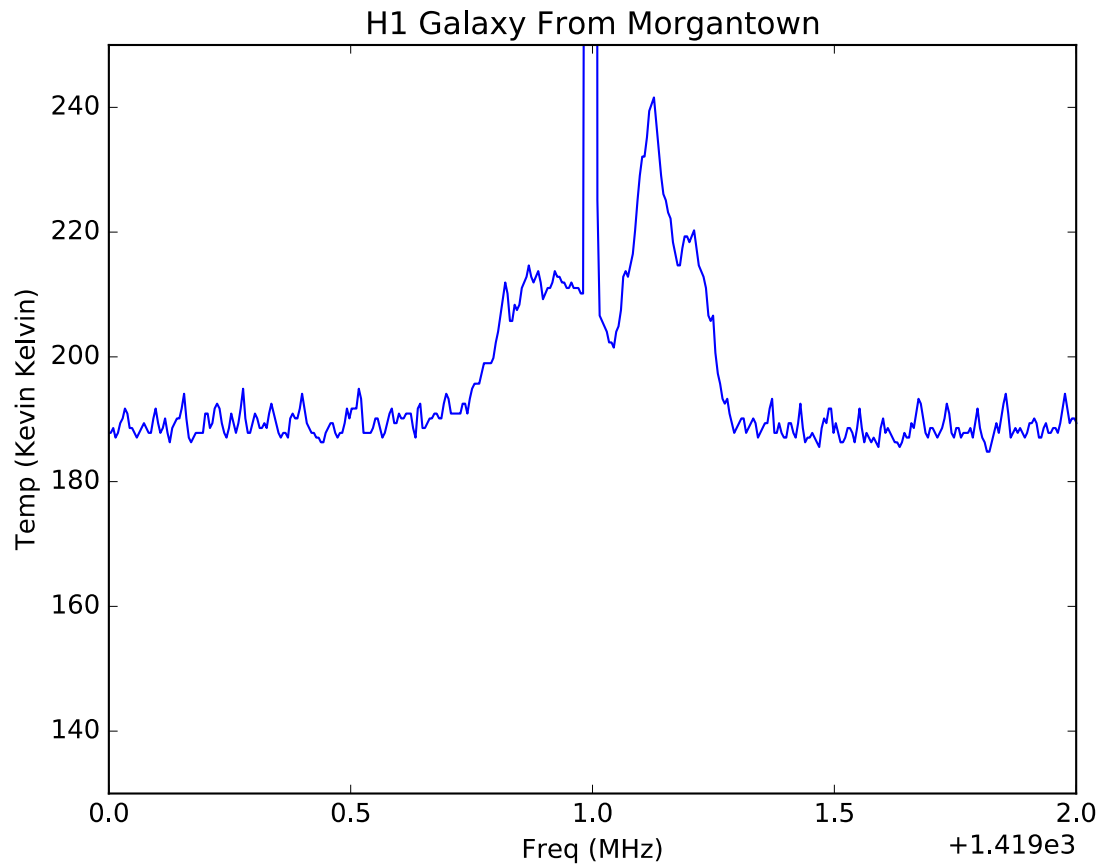

Using an 'on off' pointing at the galaxy, and point at the ground, a rough estimate is made of the system temperature. Looking at the neighboring frequencies, the system temperature was roughly 190K. The galaxy is visible at the center, with the large spike at 1420MHz due to the DC component of the sampler.